



Emerson®



Under Cabinet CD Radio

OWNER'S MANUAL

CKD1612

CAUTION

TO PREVENT FIRE OR SHOCK HAZARD, DO NOT USE THIS PLUG WITH AN EXTENSION CORD, RECEPTACLE OR OTHER OUTLET UNLESS THE BLADES CAN BE FULLY INSERTED TO PREVENT BLADE EXPOSURE. TO PREVENT FIRE OR SHOCK HAZARD, DO NOT EXPOSE THIS APPLIANCE TO RAIN OR MOISTURE.

 <p>The lightning flash with arrowhead symbol, within an equilateral triangle is intended to alert the user to the presence of uninsulated 'dangerous voltage' within the product's enclosure that may be of sufficient magnitude to constitute a risk of electric shock to persons.</p>	<p>CAUTION RISK OF ELECTRIC SHOCK DO NOT OPEN</p> <p>WARNING: TO REDUCE THE RISK OF ELECTRIC SHOCK DO NOT REMOVE COVER (OR BACK), NO USER SERVICEABLE PARTS INSIDE REFER SERVICING TO QUALIFIED SERVICE PERSONNEL.</p>	 <p>The exclamation point within an equilateral triangle is intended to alert the user to the presence of important operating and maintenance (servicing) instructions in the literature accompanying the appliance.</p>
---	--	---

The Caution Marking maybe located at the top enclosure of the apparatus.

IMPORTANT SAFETY INSTRUCTIONS

- 1.) Read these instructions. Keep these instructions. Follow all instructions. Heed all warnings.
- 2.) Before operating, make sure the voltage requirement of the unit matches your local voltage.
- 3.) Do not use this apparatus near water.
- 4.) Clean only with dry cloth.
- 5.) Install in accordance with the manufacturer's instructions.
- 6.) Do not install near any heat sources such as radiators, heat registers, stoves, or other apparatus (including amplifiers) that produce heat.
- 7.) Do not defeat the safety purpose of the polarized or grounding-type plug. A polarized plug has two blades with one wider than the other. A grounding type plug has two blades and a third grounding prong. The wide blade or the third prong is provided for your safety. If the provided plug does not fit into your outlet, consult an electrician for replacement of the obsolete outlet.
- 8.) Protect the power cord from being walked on or pinched particularly at plugs, convenience receptacles, and the point where they exit from the apparatus.
- 9.) Only use attachments / accessories specified by the manufacturer.
- 10.) Unplug this apparatus during lightning storms or when unused for long periods of time.
- 11.) Disconnect the plug as soon as immediately unplug the unit if liquid spills into or onto the unit or if an object enters the unit. The unit should not be used until being checked by experts.
- 12.) Do not open the cabinet. Lasers used in rays employed by the unit may damage your eyes. Any servicing should be done by qualified service personnel.

- 13.) Refer all servicing to qualified service personnel. Servicing is required when the apparatus has been damaged in any way, such as power-supply cord or plug is damaged, liquid has been spilled or objects have fallen into the apparatus, the apparatus has been exposed to rain or moisture, does not operate normally, or has been dropped.
- 14.) This appliance shall not be exposed to dripping or splashing water and no object filled with liquids such as vases shall be placed on the apparatus.
- 15.) Use only with the cart, stand, tripod, bracket, or table specified by the manufacturer, or sold with the apparatus.
When a cart is used, use caution when moving the cart/apparatus combination to avoid injury from tip-over.
- 16.) Do not overload wall outlet. Use only power source as indicated.
- 17.) Use replacement parts as specified by the manufacturer.
- 18.) The product may be mounted to a wall only if recommended by the manufacturer.
- 19.) Upon completion of any service or repairs to this product, ask the service technician to perform safety checks.
- 20.) Power Sources – This product should be operated only from the type of power source indicated on the marking label. If you are not sure of the type of power supply to your home, consult your product dealer or local power company. For products intended to operate from batter power, or other sources, refer to the operating instruction.
- 21.) Object and Liquid Entry – Never push objects of any kind into this product through openings as they may touch dangerous voltage points or short-out parts that could result in a fire or electric shock. Never spill liquid of any kind on the product.
- 22.) Damage Requiring Service – Unplug this product from the wall outlet and refer servicing to qualified service personnel under the following conditions.
 - a) When the power-supply cord or plug is damaged,
 - b) If liquid has been spilled, or objects have fallen into the product,
 - c) If the product has been exposed to rain or water,
 - d) If the product does not operate normally by following the operating instructions. Adjust only those controls that are covered by the operating instructions as an improper adjustment of other controls may result in damage and will often require extensive work by a qualified technician to restore the product to its normal operation.
 - e) If the product has been dropped or damaged in any way, and
 - f) When the product exhibits a distinct change in performance – this indicates a need for service.



BEFORE WE BEGIN

Thank you for purchasing this Emerson audio product, The Emerson brand is your assurance of quality, performance and value.

Our engineers have included many useful and convenient features in this product . Please be sure to read this Owner's Manual completely to make sure you are getting the maximum benefit from each feature.

This product was manufactured using the highest quality components and standards of workmanship. It was tested by Emerson inspectors and found to be in perfect working order before it left our factory. However, there is always the chance that some problem may occur because of rough handling during shipment to the retail store or to the final consumer.

If, after reading this Manual, you experience any problems with the operation of this product, please refer to the instructions for obtaining service at the end of this Manual. Emerson and Emerson retailers are committed to your satisfaction.

Once again, thanks for purchasing this Emerson audio product.

IMPORTANT NOTES

CLASS 1 LASER PRODUCT

CLASS 1 LASER PRODUCT
APPAREIL Á LASER DE CLASSE 1
PRODUCTO LASER DE CLASE 1

CAUTION
INVISIBLE LASER RADIATION
WHEN OPEN AND INTERLOCKS
DEFEATED.
AVOID EXPOSURE TO BEAM



This product contains a low power Laser Device.

- Avoid installing this unit in places exposed to direct sunlight or close to heat radiating appliances such as electric heaters, on top of other stereo equipment that radiates too much heat, places lacking ventilation or dusty areas, places subject to constant vibration and/or humid or moist areas.
- Operate controls and switches as described in the manual.
Before turning on the power, make certain that the AC power cord is properly installed.
- When moving the set, be sure to first disconnect the power cord and remove cords connected to other equipment.
- Do not leave, mount or use the unit in places which are extremely hot, cold, dusty, or humid.
- Allow adequate air circulation to prevent internal heat build-up. Do not place the unit on a surface or near materials (a curtain ex. rugs, blankets, curtains, etc.) which might block the ventilation holes.
- When left in a heated room where it is warm and damp, water droplets or condensation may form inside the CD player. When there is condensation inside the unit, the unit may not function normally. Let it stand for 1 to 2 hours before turning the power on, or gradually heat the room up and dry the unit before use.
- When you are not going to use the unit for a long period of time, disconnect the power cord.

FCC INFORMATION

This equipment has been tested and found to comply with the limits for a class B digital Device, pursuant to part 15 of the FCC Rules. These limits are designed to provide reasonable protection against harmful interference in a residential installation. This equipment generates, uses, and can radiate radio frequency energy and, if not installed and used in accordance with the instructions, may cause harmful interference to radio communications. However, there is no guarantee that interference will not occur in a particular installation. If this equipment does cause harmful interference to radio or television reception, which can be determined by turning the equipment off and on, the user is encouraged to try to correct the interference by one or more of the following measures:

- Reorient or relocate the receiving antenna.
- Increase the separation between the equipment and receiver.
- Connect the equipment into an outlet on a circuit different from that to which the receiver is connected.
- Consult the dealer or an experienced radio/TV technician for help.

This device complies with part 15 of the FCC Rules. Operation is subject to the following two conditions:

- (1) This device may not cause harmful interference, and
- (2) This device must accept any interference received, including interference that may cause undesired operation.

Changes or modifications not expressly approved by the party responsible for compliance could void the user's authority to operate the equipment.

PREPARATION FOR USE

UNPACKING AND SET UP

- Remove the unit from the carton, and remove all packing materials from the unit.
- Save the carton and packing materials in case the unit ever needs to be returned for service. Using the original carton and packing materials is the only way to safely repack the unit for shipment.
- Remove any descriptive labels or stickers from the top or front of the unit. Do not remove any labels from the back or bottom of the cabinet.
- Remove any small strips of tape that may have been used to prevent the CD door from opening in transit.

- Note the Serial Number on the bottom of your radio and write this number in the space provided on the Warranty page of this manual.
- Unwind the AC power cord and extend it to its full length.
- Place the unit on a place within easy reach of an AC outlet, out of direct sunlight, and away from sources of excessive heat, dust, moisture or humidity.

POWER SOURCE

This system is designed to operate on 120V AC ~ 60Hz house current only. Connecting this system to any other power source may cause damage to the system and such damage is not covered by your warranty.

Note: The system has polarized AC plug with one wide blade and one narrow blade. The plug will only fit into matching polarized AC outlets.

This is a safety feature to reduce the possibility of electric shock. If the plug will not fit in your AC outlet, you probably have an outdated non-polarized outlet. You should have your outdated outlet changed by a qualified, licensed electrician. Do not file the wide blade on the plug, or use an adapter to make the plug fit into your outlet. This defeats the safety feature and could expose you to electric shock.

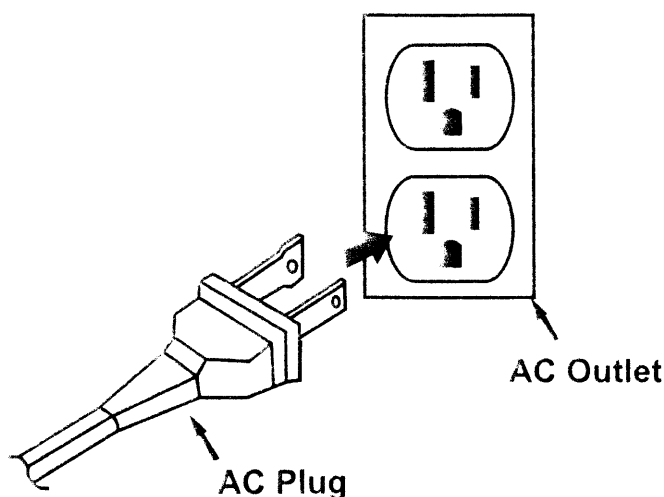

PACKAGE CONTENTS

A. (1)-Main Unit

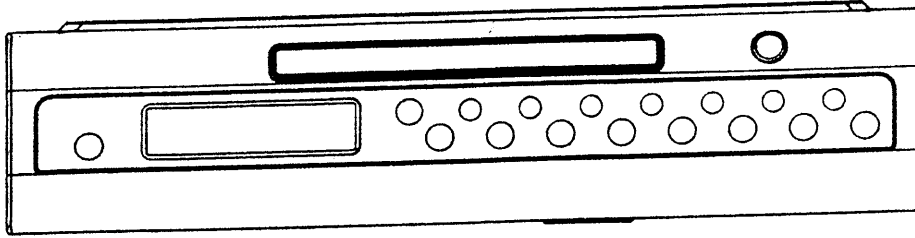

B. (1)-Mounting Template

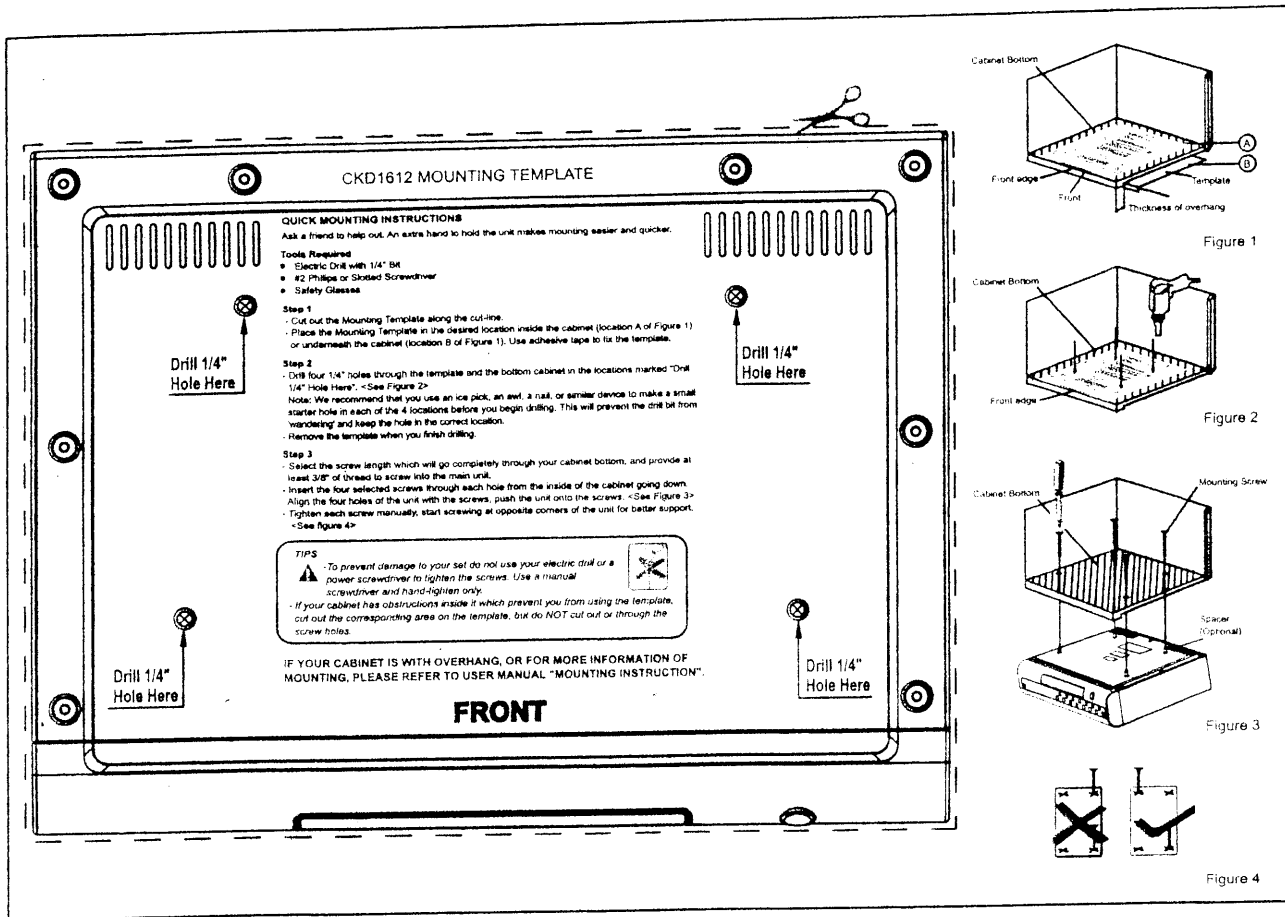

C. (1)-Remote Control

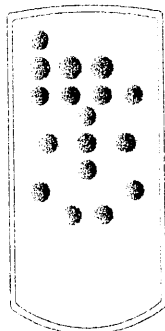

D. (4)-1.06" (27mm) spacers



E. (4)-.56" (14mm) spacers



F. (4)-.31" (8mm) spacers



G. (4)-# M 5X70mm screws



H. (4)-# M 5 X 40mm screws



I. User Manual

J. Color Insert Sheet

CAUTION

To reduce the risk of fire , do not place any heating or cooking product beneath this unit.

MOUNTING INSTRUCTIONS

Ask a friend to help out. An extra hand to hold the unit makes mounting easier and quicker.

Tools Required

- Electric Drill with 1/4" Bit
- #2 Philips or Slotted Screwdriver
- Safety Glasses

Step 1

- Cut out the Mounting Template along the cut-line.
- Place the Mounting Template in the desired location of the cabinet (location A or B of Figure 1), flush with the front edge of the cabinet. Use adhesive tape to fix the template.

(Note: If your cabinet is with overhang, fold the template along the guideline that is closest to the thickness of your cabinet overhang, tape the template with folded portion flush up against the cabinet.

<See Figure 1>)

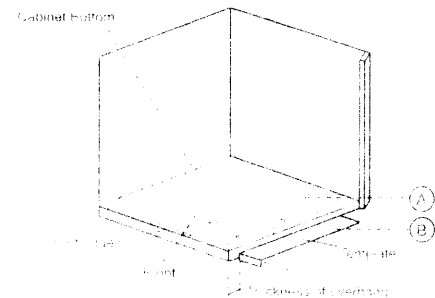

Figure 1

Step 2

- Drill four 1/4" holes through the template and the bottom cabinet in the locations marked "Drill 1/4" Hole Here". <See Figure 2>

Note: We recommend that you use an ice pick, an awl, a nail, or similar device to make a small starter hole in each of the 4 locations before you begin drilling. This will prevent the drill bit from 'wandering' and keep the hole in the correct location.

- Remove the template when you finish drilling.

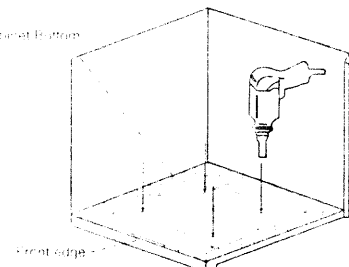

Figure 2

Step 3

- Select the screw length which will go completely through your cabinet bottom, and provide at least 3/8" of thread to screw into the main unit. (Note: If your cabinet is with overhang, put together the provided spacers to form longer spacers to accommodate various cabinet overhang thickness.)
- Insert the four selected screws through each hole from the inside of the cabinet going down. Align the four holes of the unit with the screws, push the unit (and spacers if your cabinet is with overhang) onto the screws. <See Figure 3>
- Partially tighten each screw manually, start screwing at opposite corners of the unit for better support <See figure 4>. Do not fully tighten the screw until all of them have been started. Gently tighten each screw until they are firmly holding the unit in place.

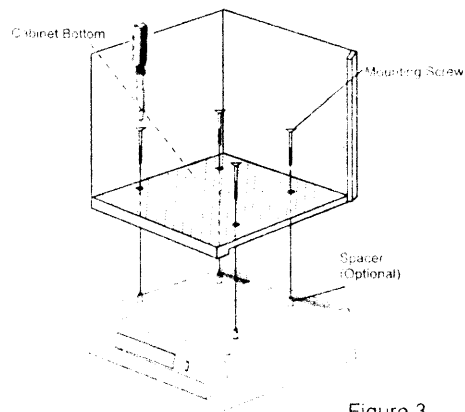

Figure 3

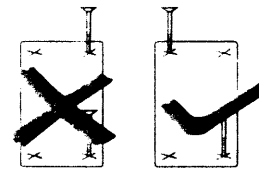

Figure 4

TIP

- To prevent damage to your set do not use your electric drill or a power screwdriver to tighten the screws. Use a manual screwdriver and hand-tighten only.
- If your cabinet has obstructions inside it which prevent you from using the template, cut out the corresponding area on the template, but do NOT cut out or through the screw holes.
- 3 sets of spacers (4 pcs/set) and 2 sets of screws (4 pcs/set) of various lengths are provided together with the unit.
- Clean the bottom of the cabinet surface and also empty your cabinet before mounting.
- Place the unit in a clean, safe place when drilling to avoid wood shavings dropping into the ventilation slots.
- To reduce splintering, please a small piece of masking tape over each hole location before drilling.
- Before you decide where and how to place your unit, try the following connections.
- Drill from the bottom upwards if you do not have enough room inside the cabinet.
- Hold your drill firmly at 90° with the cabinet bottom and drill holes at low speed.
- Clear wood shavings.

CONNECTION

Connect the AC power cord to the wall socket.

Tip: To prevent obstruction or danger, use the power cord posts to wrap the power cord so that excess cord does not hang down.

LOCATION OF CONTROLS AND INDICATORS

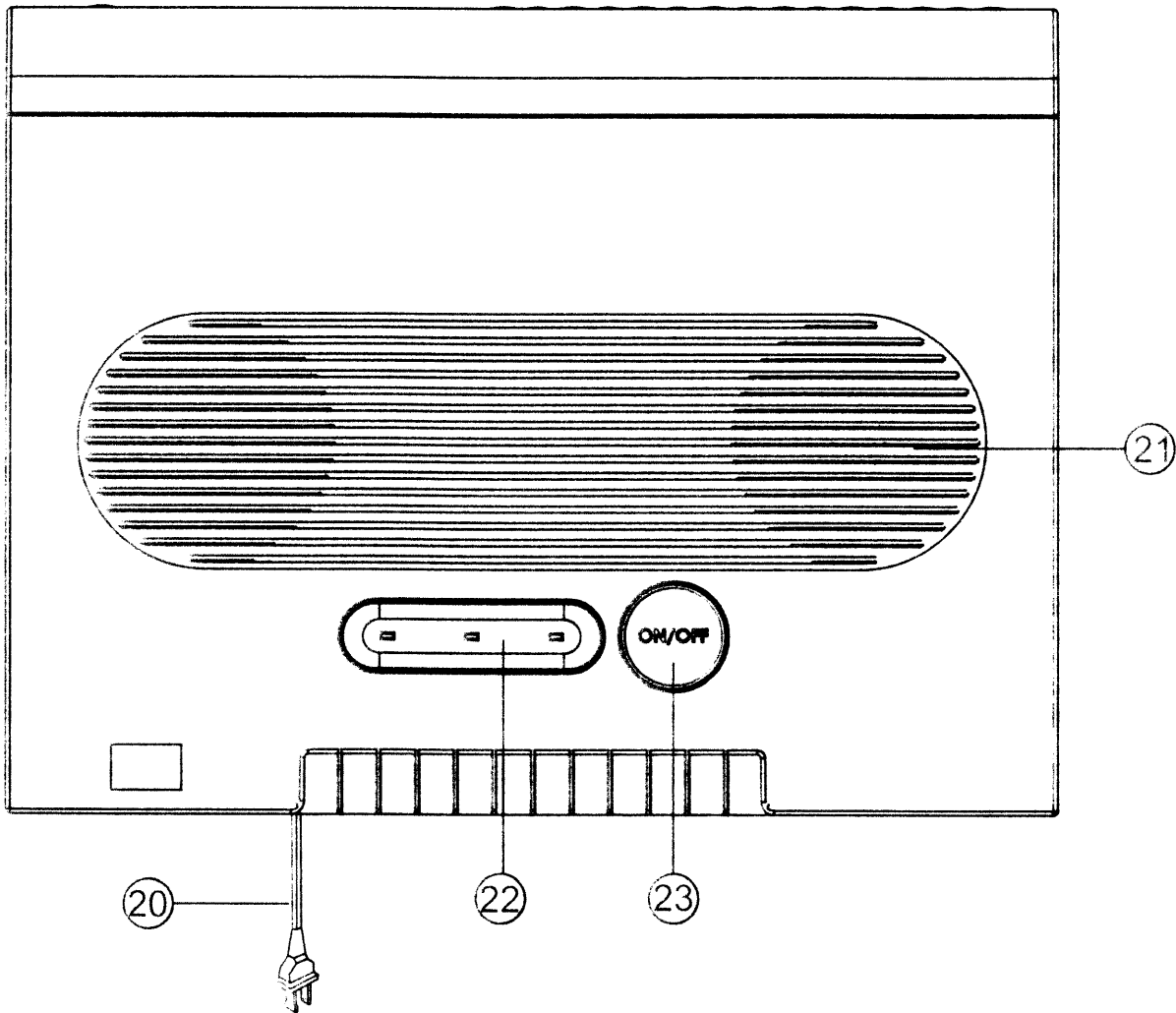
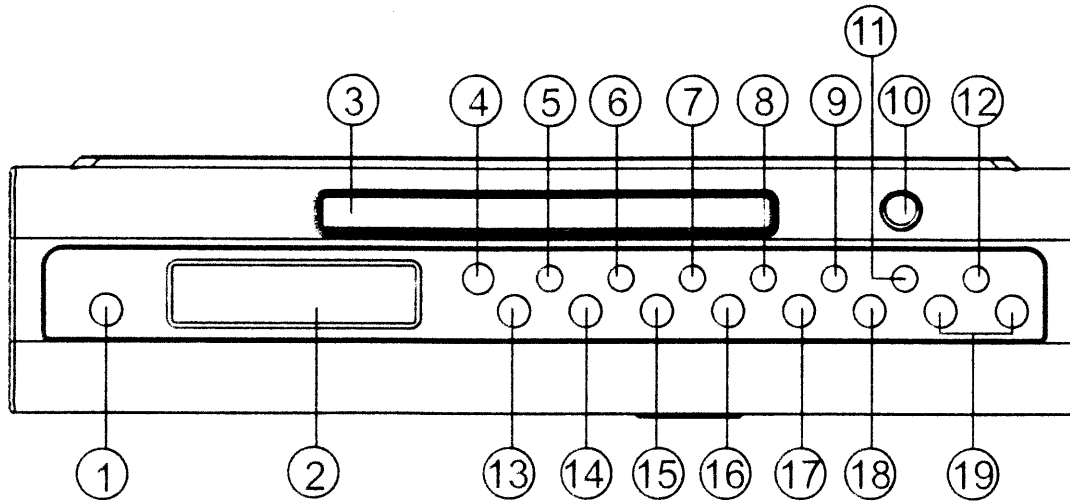

MAIN UNIT

1. **ON / OFF** button
2. LCD display
3. CD compartment
4. Remote Sensor
5. Cooking Timer +10 (min) / Cooking Timer Off button
6. Cooking Timer +1 (min) button
7. **Preset –** button
8. **Preset +** button
9. **M** (Memory) / **Set** button
10. **Open / Close** button
11. **Stereo / Mono / Repeat** button
12. **Random** button
13. **Function (CD / Tuner)** switch
14. **Stop ■** button
15. **Play / Pause ►||** button / **Band** switch
16. **◀◀** Tuning- / CD Skip Reverse Search button
17. **▶▶** Tuning+ / CD Skip Forward Search button
18. **XBASS** button
19. Volume -/+ button
20. Power AC cord
21. Speaker
22. Counter Top Lighting
23. Counter Top Lighting **ON/OFF** switch

REMOTE CONTROL

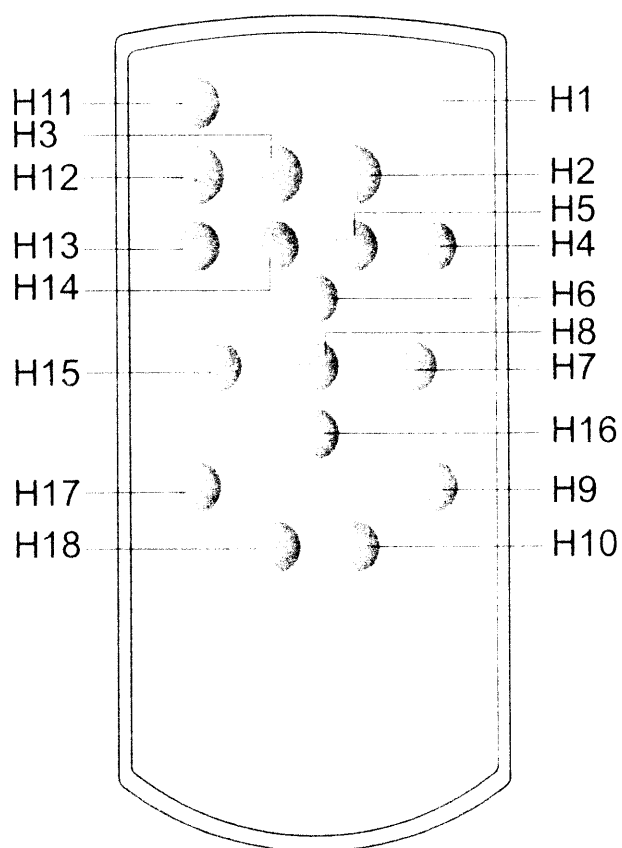

H1. Power ON/OFF button

H2. **Random** button

H3. **Repeat / Stereo / Mono** button

H4. ►► Tuning+ / CD Skip Forward Search button

H5. ◀◀ Tuning- / CD Skip Reverse Search button

H6. Volume + button

H7. **M-UP** (memory up) button

H8. **Function** (CD/Tuner) switch

H9. **Open / Close** button

H10. Cooking Timer +1 (min) button

H11. **Mute** button

H12. **MEMO** (Memory) / Set button

H13. Play / Pause ►| button / Band switch

H14. Stop ■ button

H15. **M-DN** (memory down) button

H16. Volume - button

H17. **XBASS** button

H18. Cooking Timer +10 (min) Cooking Timer Off button

USING THE REMOTE CONTROL CORRECTLY

- Point the Remote Control at the REMOTE SENSOR located on the unit.
- When there is a strong ambient light source, the performance of the infrared REMOTE may be degraded, causing unreliable operation.
- The recommended effective distance for remote operation is about 13 feet (4m).

ATTENTION

A MAGNET IS BUILT INTO THE REMOTE CONTROL SO THAT IT CAN BE ATTACHED TO YOUR REFRIGERATOR.

- Remove the battery insulation tab before operating the remote control.
- When the battery becomes weak, the operating distance of the Remote Control is greatly reduced and you will need to replace it as follow:
 1. Turn over the remote and open the battery door.
 2. Insert one CR2025 (3V) size lithium battery.
- Dispose of used batteries in accordance with local laws and regulations.

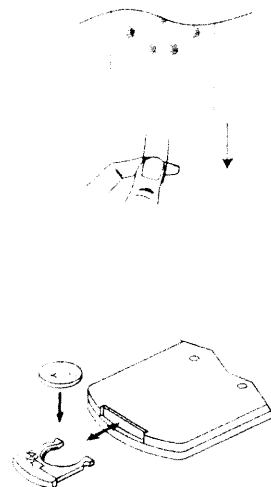

WARNING: DANGER OF EXPLOSION IF BATTERY IS INCORRECTLY REPLACED, REPLACE ONLY WITH THE SAME OR EQUIVALENT TYPE.

DISPLAY

- D1. Stereo indicator
- D2. TUNER indicator
- D3. CD indicator
- D4. RPT indicator (repeat)
- D5. XBASS indicator
- D6. RDM indicator (random)
- D7. MEMORY indicator
- D8. FM indicator
- D9. AM indicator
- D10. PM indicator
- D11. Frequency / Clock / Track indicator
- D12. Play indicator
- D13. MUTE indicator
- D14. Volume indicator
- D15. Cooking Timer indicator

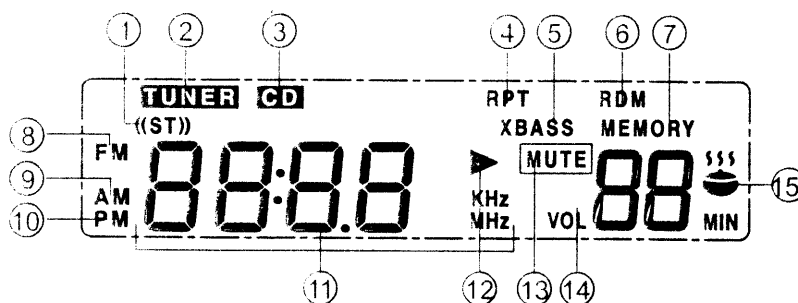

COUNTER TOP LIGHT

The countertop light and its ON/OFF switch are located on the bottom of the unit. Press ON/OFF switch to turn the LIGHT on and off.

OPERATING INSTRUCTION

SETTING THE CLOCK

To set the clock time, make sure the unit is plugged in and in standby mode.

- 1.) Press the **M / Set** button until "12H" or "24H" blinks.
- 2.) Press **◀** or **▶** to set your desired clock format and press **M / Set** to confirm. Hour position blinks for setting.



- 3.) Press the **◀** or **▶** to set the current hour (for example to set 2:00 PM), press **M / Set** to confirm. Minute position blinks for setting.

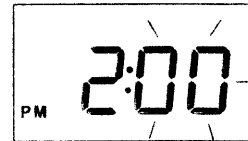

- 4.) Press the **◀** or **▶** to set the current minute, press **M / Set** to confirm. And the clock start.

Note: The clock will be started automatically if no button is pressed within 10 seconds during setting.

LISTENING TO THE RADIO

Tuning to a station manually

- 1.) Press the **POWER** button to turn on the unit.
- 2.) Press the **FUNCTION (CD/Tuner)** switch until TUNER is displayed.
- 3.) Press the **BAND** switch to select AM or FM.
- 4.) Press the **◀ / ▶** buttons to tune to a desired station.

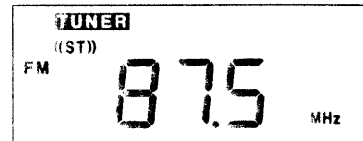

To quickly search for a station

Press and hold the **◀ / ▶** button until the tuner starts searching for a station, then release. The tuner will stop on the next well received station.

To turn off the radio

Press the **FUNCTION (CD/Tuner)** switch to CD or press the **POWER** button to turn the unit off.

To improve radio reception

For FM, extend and adjust the AC power cord.

SETTING A PRESET RADIO STATION

The unit can store totally 40 stations in memory (20 FM, 20 AM). Presetting allows you to tune in to a station directly.

- 1.) Tune to your desired radio station (see **Tuning to a station manually**).
- 2.) Press the **M/Set** button until the "MEMORY" blinks and "01" appears in the display. The "01" is the order of the preset station (1-20).
- 3.) Or you may press the Preset \blacktriangledown or \blacktriangle (+ or -) button on Front Panel or M-UP or M-DN on remote control to select your desired preset station number.
- 4.) Press the **M/Set** button to store the station.
- 5.) Repeat step 1.) to 4.) for the preset stations.

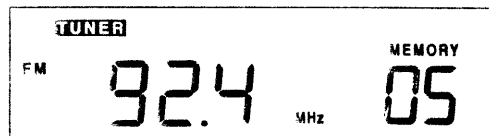
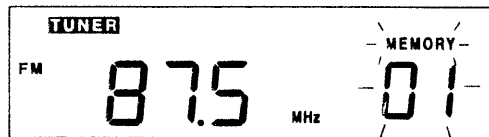

Helpful hints: If you store more than 20 FM stations, the new stations will replace the 1st preset stations.

TO LISTEN TO A PRESET RADIO STATION

- 1.) Press the **FUNCTION (CD/Tuner)** switch until TUNER is displayed.
- 2.) Press the **BAND** button to select AM/FM.
- 3.) Press the **PRESET +** or **-** button on Front Panel or M-DN / M-UP on remote control unit to select the preset station.

PLAYING COMPACT DISCS

- 1.) Press the **ON/OFF** button to turn ON the unit.
- 2.) Press the **Function (CD / Tuner)** switch to select playing in CD mode.
- 3.) Press the \blacktriangle **OPEN/CLOSE** button to open the CD drawer. Place a CD onto the CD tray with the label side up and then press the \blacktriangle **OPEN/CLOSE** button to close it. The CD will be scanned and the total number of tracks will be displayed.
- 4.) Press the \blacktriangleright **PLAY/PAUSE** button to start playing the CD. The current track appears in the display.
- 5.) Adjust volume by pressing the **VOLUME +/-** buttons.

Note: Do not push the CD drawer to close it.

To pause playback

- 1.) Press the \blacktriangleright **PLAY/PAUSE** button, \blacktriangleright indicator blinks, and playback is paused.
- 2.) To resume playback, press the \blacktriangleright **PLAY/PAUSE** button again.

To stop playback

Press \blacksquare **STOP** button, total track number appears, and playback stops.

To skip to different track

- 1.) To SKIP to the beginning of the current track, press the \blacktriangleleft button once.
- 2.) To SKIP to any earlier track, press the \blacktriangleleft button certain times to reach.
- 3.) To SKIP to any later track, press the \blacktriangleright button certain times to reach.

To fast forward or fast reverse to particular point

- 1.) To scan forward at high speed, press and hold the ►► button and release it at the desired point.
- 2.) To scan backward at high speed, press and hold the ◀◀ button and release it at the desired point.

Repeat playback

This function will allow a single track or the entire CD to be played repeatedly.

1) To repeating the current track

- Press the **REPEAT** button until “RPT” blinks, the current track will be played repeatedly.
- Select a desired different track to be repeated by pressing the ►► / ◀◀ button.

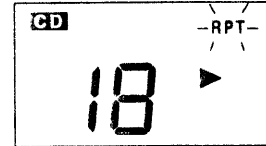

2) To repeat the entire CD

- Press the **REPEAT** button until “RPT” alight. All tracks will be played repeatedly.

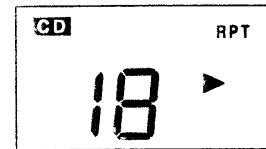

3) To cancel repeat play

- Press the **REPEAT** button until “RPT” disappears.

CD random playback

This function will allow to play the CD in randomly order.

Note: Random playback can only be selected while the player is in the stop mode.

- 1) Press the **RANDOM** button to play the tracks in random order, “RDM” indicator appears in the display, press ►► button, random playback starts. When all tracks have been played, the player stops and the display shows the total tracks.

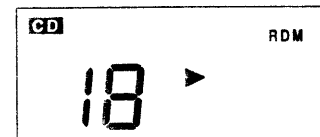

- 2) To cancel Random playback, press STOP ■ button, the display shows total tracks, "RDM" indicator disappears from the display.

CD programmable playback

1) To program as desired

A program of up to 20 tracks can be programmed to play in a preset order.

- a. When the unit is ON and in the CD MODE, make sure the CD is STOPPED.
Press the **M/Set** button. “0” and “MEMORY” will blink in the display.
- b. Press the ◀◀ / ►► buttons to select the desired track.
For example, to play track NO.2 first, the display would look like this:

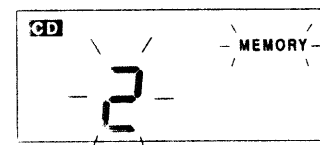
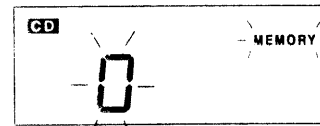

- c. Press the **M/Set** button to store the track in memory.
- d. To add additional tracks, repeat steps b&c (up to 20 tracks).
- e. To start playback, press the ►|| **PLAY/PAUSE** button.

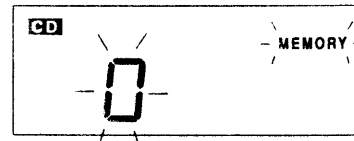

2) To check the program

- After setting, press the ►|| **PLAY/PAUSE** button to start playing, then press the ◀◀/▶▶ buttons to check the programmed tracks; or in STOP mode, press **M/Set** button repeatedly to check the programmed tracks.

3) To add additional tracks during program mode:

- Press the **M/Set** button repeatedly until the number of the last programmed track appears and repeat steps b to d above.

4) To change the programmed tracks during program mode:

- Press the **M/Set** button repeatedly to select the number of the program, then press the ◀◀/▶▶ buttons to alter the track. Press the **M/Set** button to register the newly programmed track into memory.

5) To erase the whole program, do one of the following:

- Press the **STOP** ■ button, or
- Open the CD compartment by pressing the ▲ **OPEN/CLOSE** button.

Note: You can use REPEAT function during PROGRAM PLAY.

XBASS FUNCTION

Press **XBASS** to activate XBASS function during playing. “XBASS” indicator appears on the display.

SETTING THE COOKING TIMER

- 1.) Press the **TIMER (+10 or +1)** buttons to select your desired time from 1-99 minutes. COOKING TIMER indicator blinks.

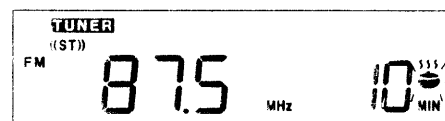

- 2.) When the preset time elapses, the ALARM will sound.

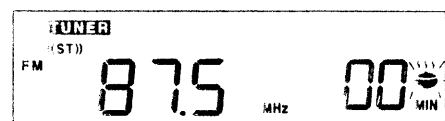

CANCELLATION OF COOKING TIMER

if you want to cancel the preset COOKING TIMER:

- When it's counting down, press and hold **Timer Off** button for 2 seconds.
- When the preset time elapses, and the Alarm is ringing, just press **Timer Off** button. Otherwise the ALARM will automatically turn off after 60 minutes if no button is pressed.

MUTE FUNCTION

To cut off the sound from speaker temporarily, press the **MUTE** button, MUTE indicator appears on the display. Press **MUTE** button again to cancel mute function and restore the sound from speaker.

CARE AND MAINTENANCE

COMPACT DISC CARE

- To remove a disc from its storage case, press down on the center of the case and lift the disc out, holding it carefully by the edges.

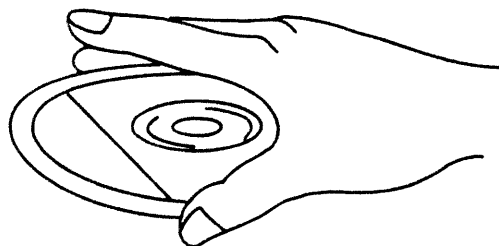
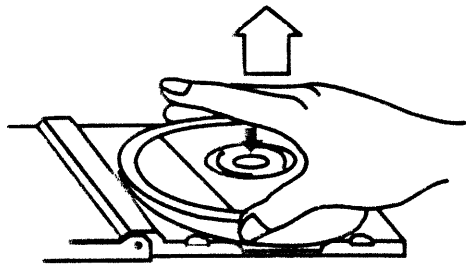

- Fingerprints and dust should be carefully wiped off the disc's recorded surface with a soft cloth. Unlike conventional records, compact discs have no grooves to collect dust and microscopic debris, so gently wiping with a soft cloth should remove most particles. Wipe in a straight line from the inside to the outside of the disc. Small dust particles and light stains will have absolutely no effect on reproduction quality.

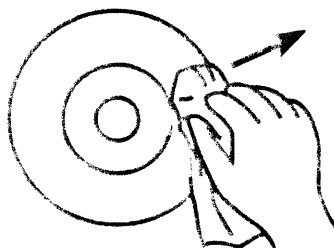
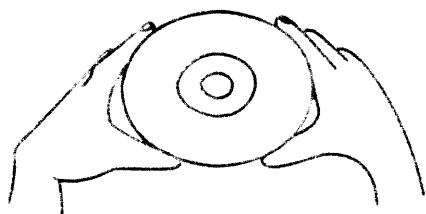

- Clean the disc periodically with a soft, lint-free, dry cloth. Never use detergents or abrasive cleaners to clean the disc. If necessary, use a CD cleaning kit.
- Never write on or affix labels to the surface of compact discs.

CAUTION

Never allow any water or other liquids to get inside the unit while cleaning.

To reduce the risk of fire, do not place any heating or cooking product beneath this unit.

CLEANING THE UNIT

- Do not use volatile chemicals on this unit. Clean by lightly wiping with a dry soft cloth.
- Keep the CD Drawer closed to keep dust out of the unit.

HANDLING THE CD

- Only touch the CD on the edge to avoid finger prints on the underside of the CD.
- Do not stick paper or tape on the underside of the CD, and do not write anything on the underside of the disc.

CD LENS CARE

- When your CD lens gets dirty it can also cause the unit to output poor sound quality. To clean the lens you will need to purchase a CD lens cleaner. For instructions on cleaning the CD lens, refer to the instructions accompanying the CD lens cleaner.

TROUBLE SHOOTING GUIDE

Should this unit exhibit a problem, check the following before seeking service.

"--" appears on the display.	No disc inserted. Insert a suitable disc. Replace/clean CD. CD-R(W) is blank or disc is not finalized. Moisture has condensed in the player. Remove the disc and leave the player power-on until the moisture evaporates.
NO SOUND.	Check whether the set is connected securely. Make sure the set is not in the MUTE mode. If it is, press MUTE to turn on the speaker. Check whether the volume on the set has been set to the lowest level. If it has, turn up the volume. CD-ROM disc inserted/CD contains non-audio files. Use CD Audio discs only.
The system does not react when buttons are pressed.	Remove and reconnect the AC power plug and switch on the system again.
Remote control does not work.	Remove the protective plastic tab before using the remote control. Reduce the distance between the remote control and the set. Replace the battery. Point the remote control directly towards the remote sensor.
Radio reception is poor.	The FM antenna is built in to the AC power cord .If FM reception is weak try varying the position and direction of the power cord until you find the strongest signal.
The Clock setting is erased.	Power has been interrupted or the power cord has been disconnected. Reset the clock.

CARE AND MAINTENANCE

There are no user serviceable parts inside this radio.

Please refer all service problems to a qualified service facility.

Care Of Cabinets

If the cabinet becomes dusty the exterior with a soft dust cloth only.
Never use dusting sprays or polishes on the cabinet.

If the cabinet becomes dirty or smudged with fingerprints it may be wiped with a soft cloth that has been slightly dampened with a mild soap and water solution.

Always disconnect the AC power cord from the AC outlet before cleaning, and never allow any liquid to get inside the cabinet.



Emerson[®]

SERVICE

TO FIND THE LOCATION AND PHONE NUMBER OF YOUR NEAREST SERVICE CENTER PERMITTED TO PERFORM WARRANTY...

CALL TOLL FREE: 1-800-695-0098

FOR ADDITIONAL SET-UP OR OPERATING ASSISTANCE
PLEASE CALL:
1-800-898-9020

FOR CUSTOMER SERVICE, PLEASE WRITE TO:
Emerson Radio Corp.,
Consumer Affairs Dept.,
5101 Statesman Drive,
Irving, TX 75063.

LIMITED WARRANTY

Emerson Radio Corp. warrants manufacturing defects in original material, including original parts and workmanship, under normal use and conditions, for a period of ninety (90) days from the date of original purchase in the U.S. With your dated proof of purchase, we will provide repair service at no charge for labor and parts at an authorized Depot Repair Facility, or replace the product in our discretion. For repair or replacement, pack your unit in a padded box, enclose your check or money order payable to Emerson Radio Corp. in the amount of \$9.00 (not required by California residents) to cover shipping and handling costs, and enclose a copy of your proof of purchase. Send your unit to:

Emerson Radio Corp.,
5101 Statesman Drive,
Irving, TX 75063.

This warranty does not cover damage from negligence, misuse, abuse, accident, failure to follow operating instructions, commercial use, rental, repairs by an unauthorized facility, or products purchased, used, serviced or damaged outside of the United States.

THIS WARRANTY GIVES YOU SPECIFIC LEGAL RIGHTS, AND YOU MAY ALSO HAVE OTHER RIGHTS WHICH VARY FROM STATE TO STATE.

AU898M

The Serial Number of this unit is located on the label on the back of the cabinet.

Please take a moment now to write this Serial Number in the space provided below.

You may be asked for this number when calling for service assistance.

Model No: **CKD1612**

Serial Number: _____

